

MAGNUM[®]

PRO SERIES TRASH CANS & DUMP CARTS



NOW IN SAFETY BLUE



**HEAVY-DUTY UNIVERSAL
TRASH CAN DOLLIES**

WE HANDLE IT™



888.443.8889



MAGNUM-TOOL.COM

UNFAILING

MAGNUM

PRO SERIES TRASH CANS

Expect excellent quality, innovative features, and superior functionality without sacrificing durability and value. Welcome to **Magnum Pro Series**, professional-grade equipment that works hard and stands up to daily work site punishment.



FEATURES & BENEFITS

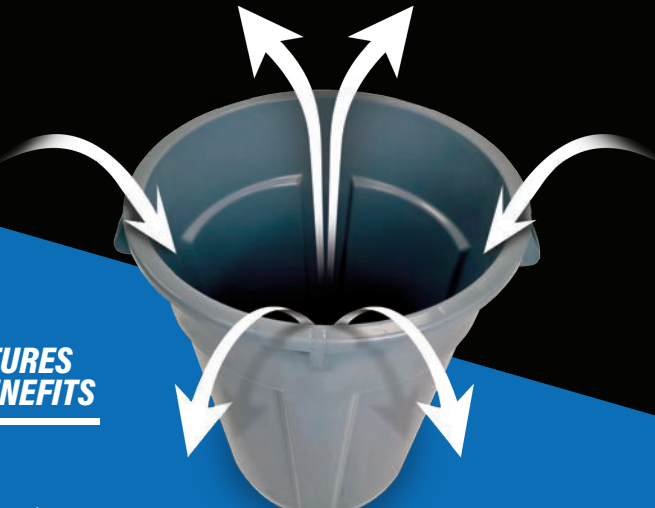

AIR CHANNELS

allow for optimal airflow in and out of the trash can, making bag removal and trash can stacking a breeze, not a time consuming challenge.



BAG CINCHES

help secure your bag to eliminate poor fitment and messy clean up.



MASSIVE REINFORCEMENT

for added strength and long-lasting durability.

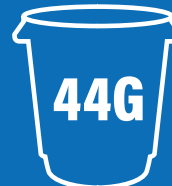

SEE ALL SIZES & COLORS | PG. 4

NEW

NOW AVAILABLE IN BLUE

Same unfailing durability, all-new color. Provide immediate visual differentiation from regular waste with blue color coding to improve recycling, or match your company colors. Lids to match! And don't forget our Heavy-Duty Universal Dolly to keep things rolling!

SEE ALL SIZES & COLORS | **PG. 4**



NEW

KEEP IT ROLLING WITH RUGGED DURABILITY.

HEAVY-DUTY UNIVERSAL TRASH CAN DOLLY | **PG. 5**

- One size fits all Magnum Pro-Series Trash Cans, and most major brands
- Massive structural reinforcement to base
- Commercial grade casters
- Easy and secure fitment



MAGNUM



MATERIAL HANDLING

PRO SERIES

TRASH CANS

- New sizes and colors! Now available in 32, 44 & 55 gallon capacities, each offered in four colors (Gray, Yellow, Red and Blue)
- Air channels maximize airflow to reduce suction and make bag removal a breeze
- Built-in bag cinches to secure liner
- Massively reinforced, jobsite ready trash cans
- Ergonomic built-in handles for comfort and easy handling
- Lids and dollies available as optional accessories



ITEM CODE	DESCRIPTION	SIZE	COLOR	SHIPPING DIMENSIONS	ITEM WEIGHT	PALLET COUNT	PURCHASE UNIT
CMTC-C-32G	PRO SERIES TRASH CAN	32 GALLON	GRAY	26" X 22" X 28"	9 LB	48	1 TRASH CAN
CMTC-C-44G	PRO SERIES TRASH CAN	44 GALLON	GRAY	28" X 24" X 31"	11.6 LB	48	1 TRASH CAN
CMTC-C-55G	PRO SERIES TRASH CAN	55 GALLON	GRAY	30" X 27" X 33"	15.2 LB	48	1 TRASH CAN
CMTC-C-32Y	PRO SERIES TRASH CAN	32 GALLON	YELLOW	26" X 22" X 28"	9 LB	48	1 TRASH CAN
CMTC-C-44Y	PRO SERIES TRASH CAN	44 GALLON	YELLOW	28" X 24" X 31"	11.6 LB	48	1 TRASH CAN
CMTC-C-55Y	PRO SERIES TRASH CAN	55 GALLON	YELLOW	30" X 27" X 33"	15.2 LB	48	1 TRASH CAN
CMTC-C-32R	PRO SERIES TRASH CAN	32 GALLON	RED	26" X 22" X 28"	9 LB	48	1 TRASH CAN
CMTC-C-44R	PRO SERIES TRASH CAN	44 GALLON	RED	28" X 24" X 31"	11.6 LB	48	1 TRASH CAN
CMTC-C-55R	PRO SERIES TRASH CAN	55 GALLON	RED	30" X 27" X 33"	15.2 LB	48	1 TRASH CAN
CMTC-C-32B	PRO SERIES TRASH CAN	32 GALLON	BLUE	26" X 22" X 28"	9 LB	48	1 TRASH CAN
CMTC-C-44B	PRO SERIES TRASH CAN	44 GALLON	BLUE	28" X 24" X 31"	11.6 LB	48	1 TRASH CAN
CMTC-C-55B	PRO SERIES TRASH CAN	55 GALLON	BLUE	30" X 27" X 33"	15.2 LB	48	1 TRASH CAN

TRASH CAN LIDS

**ALL SIZES.
ALL COLORS.**



PRO SERIES TRASH CAN LIDS

- Great fitment on Pro Series Trash Cans
- Securely snaps shut and opens easily
- Available in all sizes and colors



ITEM CODE	DESCRIPTION	SIZE	COLOR	ITEM WEIGHT	BOX COUNT	PURCHASE UNIT
CMTC-L-32G	PRO SERIES TRASH CAN LID	32G	GRAY	2 LB	10	1 LID
CMTC-L-44G	PRO SERIES TRASH CAN LID	44G	GRAY	2 LB	10	1 LID
CMTC-L-55G	PRO SERIES TRASH CAN LID	55G	GRAY	3.2 LB	10	1 LID
CMTC-L-32Y	PRO SERIES TRASH CAN LID	32G	YELLOW	2 LB	10	1 LID
CMTC-L-44Y	PRO SERIES TRASH CAN LID	44G	YELLOW	2 LB	10	1 LID
CMTC-L-55Y	PRO SERIES TRASH CAN LID	55G	YELLOW	3.2 LB	10	1 LID
CMTC-L-32R	PRO SERIES TRASH CAN LID	32G	RED	2 LB	10	1 LID
CMTC-L-44R	PRO SERIES TRASH CAN LID	44G	RED	2 LB	10	1 LID
CMTC-L-55R	PRO SERIES TRASH CAN LID	55G	RED	3.2 LB	10	1 LID
CMTC-L-32B	PRO SERIES TRASH CAN LID	32G	BLUE	2 LB	10	1 LID
CMTC-L-44B	PRO SERIES TRASH CAN LID	44G	BLUE	2 LB	10	1 LID
CMTC-L-55B	PRO SERIES TRASH CAN LID	55G	BLUE	3.2 LB	10	1 LID

TRASH CAN DOLLY

ONE SIZE FITS ALL.



HEAVY-DUTY UNIVERSAL TRASH CAN DOLLY

Universal design. One size fits all Pro Series Trash Cans and most major brand trash cans. Designed with massive structural reinforcements for improved longevity and transportation of heavy refuse.



Smooth rolling, non-marking casters

ITEM CODE	DESCRIPTION	COLOR	WEIGHT	BOX COUNT	PURCHASE UNIT
CATC-DG-HD	H.D. 20/32/44/55G TRASH CAN DOLLY	GRAY	6.9 LB	6	1 DOLLY

MAGNUM

DUMP CARTS

Engineered for industrial and commercial use, these durable injection-molded tubs support load capacities ranging from 750 to 1,250 lbs. Available in 1/2 cubic yard and 1 cubic yard covered capacity, each dump cart is built with a variety of reinforced frame options to meet demanding jobsite needs.

Designed for smooth maneuverability and equipped with robust wheel and caster configurations, these carts are also easily stackable, ensuring efficient storage and transport.

OPTIONAL LID

RUGGED & DURABLE
CONSTRUCTION

REINFORCED
EDGES

A VARIETY
OF FRAME
OPTIONS

DOUBLE
INJECTION
MOLD

HEAVY-DUTY & NON-MARKING
CASTER & WHEEL OPTIONS



MAGNUM



EASY STACKING. EFFICIENT STORAGE.

MAGNUM

WE HANDLE IT™



888.443.8889



MAGNUM-TOOL.COM

DUMP CARTS

- Premium injection molded tubs for added strength in corners
- Smooth surface is easy to clean and resists corrosion
- Fits through standard doorways and elevators
- Handling can be performed by a single user
- Construction grade wheels and casters



1/2 Cubic Yard Dump Cart

750 LB LOAD CAPACITY

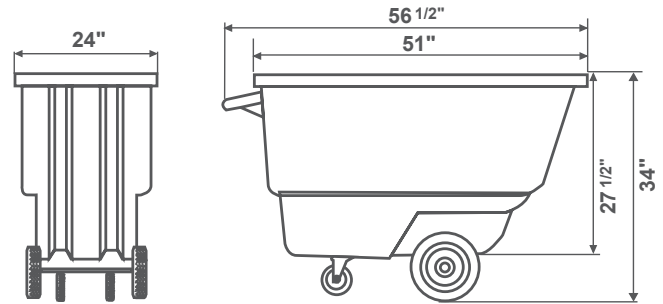

ITEM CODE	CASTER TYPE	WHEEL TYPE	ITEM WEIGHT	PALLET COUNT
DUC12T	4" HEAVY-DUTY	10" HEAVY-DUTY	64 LB	14
DUC12T-NM*	5" NON-MARKING	12" NON-MARKING	48 LB	14

*Use 2-5/8" Axle (DUA12-575)

1 Cubic Yard Covered Capacity Dump Cart

800 LB LOAD CAPACITY

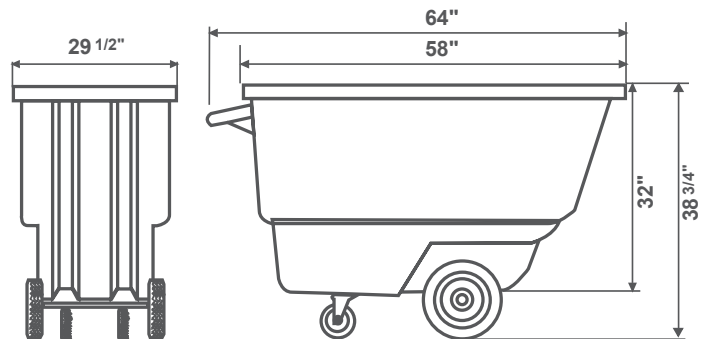

ITEM CODE	CASTER TYPE	WHEEL TYPE	ITEM WEIGHT	PALLET COUNT
DUC100-12	5" HEAVY-DUTY	12" HEAVY-DUTY	89 LB	12
DUC100-12-NM	5" NON-MARKING	12" NON-MARKING	73 LB	12



**1 Cubic Yard Covered Capacity Dump Cart w/
Reinforcing Frame**

UP TO 1000 LB LOAD CAPACITY

ITEM CODE	CASTER TYPE	WHEEL TYPE	LOAD CAPACITY	ITEM WEIGHT	PALLET COUNT
DUC100-R	5" HEAVY-DUTY	12" HEAVY-DUTY	1000 LB	94 LB	12
DUC100-R-NM	5" NON-MARKING	12" NON-MARKING	900 LB	78 LB	12



**1 Cubic Yard Covered Capacity Dump Cart w/
Heavy-Duty Full Frame**

UP TO 1200 LB LOAD CAPACITY

ITEM CODE	CASTER TYPE	WHEEL TYPE	LOAD CAPACITY	ITEM WEIGHT	PALLET COUNT
DUC100-H	5" HEAVY-DUTY	12" HEAVY-DUTY	1200 LB	112 LB	10
DUC100-H-NM	5" NON-MARKING	12" NON-MARKING	950 LB	96 LB	10

**MAGNUM HEAVY-DUTY
FORKLIFT READY DUMP CARTS**



**UP TO
1250 LB LOAD
CAPACITY**

Compatible with forklifts an automated lifters. Features a heavy-duty forklift ready frame that is built to last.



ITEM CODE	DESCRIPTION	LOAD CAPACITY	CASTER TYPE	WHEEL TYPE	ITEM WEIGHT	PALLET COUNT
DUC12T-F	1/2 CU. YD. FORK LIFT READY DUMP CART, HD	850 LB	5" HEAVY-DUTY	12" HEAVY-DUTY	79 LB	8
DUC12T-F-NM	1/2 CU. YD. FORK LIFT READY DUMP CART, NM	850 LB	5" NON-MARKING	12" NON-MARKING	63 LB	8
DUC100-F	1 CU. YD. COVERED CAPACITY FORKLIFT READY DUMP CART, HD	1250 LB	5" HEAVY-DUTY	12" HEAVY-DUTY	103 LB	7
DUC100-F-NM	1 CU. YD. COVERED CAPACITY FORKLIFT READY DUMP CART, NM	1000 LB	5" NON-MARKING	12" NON-MARKING	87 LB	7

Premium steel powder coated frames resist corrosion.

DUF100R

Reinforcing Frame for 1 Cubic Yard Covered Capacity Dump Cart

Add to any existing 1 CU. YD. Covered Capacity Dump Cart. No additional hardware needed.



ITEM WEIGHT
5 LB

PURCHASE UNIT
1 FRAME

DUF100H

Heavy Duty Frame for 1 Cubic Yard Covered Capacity Dump Cart

Add to any existing 1 CU. YD. Covered Capacity Dump Cart. No additional hardware needed.



ITEM WEIGHT
23 LB

PURCHASE UNIT
1 FRAME

DUF12F-K

Forklift Ready Frame Kit for 1/2 Cubic Yard Dump Cart

Includes: (1) Forklift Ready Frame, (2) Heavy-Duty 5" Casters, (2) Heavy-Duty 12" Wheels and (1) DUA12-575 Axle.



ITEM WEIGHT
18 LB

PURCHASE UNIT
1 FRAME

DUF100F

Forklift Ready Frame for 1 Cubic Yard Covered Capacity Dump Cart

Add to any existing 1 CU. YD. Covered Capacity Dump Cart. No additional hardware needed.



ITEM WEIGHT
21 LB

PURCHASE UNIT
1 FRAME

DUMP CART LIDS & ACCESSORIES

DUMP CART FABRIC LIDS



DUL12T-F

Soft Fabric Lid for Magnum 1/2 Cubic Yard Dump Cart

DIMENSIONS 51" X 29" X 6.75"
ITEM WEIGHT 3.50 LB

DUL-F

Universal Soft Fabric Lid for 1 Cubic Yard Covered Capacity Dump Cart

DIMENSIONS 67" X 29" X 6.75"
ITEM WEIGHT 3.75 LB

DUL100-F

Soft Fabric Lid for Magnum 1 Cubic Yard Covered Capacity Dump Cart

DIMENSIONS 55" X 29" X 6.75"



DUMP CART PLASTIC LIDS

Plastic Lid for 1/2 Cubic Yard Dump Cart

DUL12T

ITEM WEIGHT 12 LB
PURCHASE UNIT 1 LID

Plastic Lid for 1 Cubic Yard Covered Capacity Dump Cart

DUL100

ITEM WEIGHT 17 LB
PURCHASE UNIT 1 LID

DUMP CART AXLES



ITEM CODE	WORKS WITH	AXLE LENGTH	WEIGHT	BOX COUNT	PURCHASE UNIT
DUA12-550	1/2 CU. YD. CART	21-5/8"	3 LB	1	1 AXLE
DUA12-575*	1/2 CU. YD. CART	22-5/8"	3.3 LB	1	1 AXLE
DUA100-12	1 CU. YD. COVERED CAPACITY CART	24-3/8"	4 LB	1	1 AXLE

*Use this axle on 1/2 cubic yard dump carts (DUC12T-NM and DUC12T-F) when using 5" non-marking casters (CAS5PS-NM) & 12" non-marking wheels (CAS12-NM).



DUMP CART PLATE CASTERS

ITEM CODE	CASTER TYPE	WHEEL DIAMETER	WHEEL WIDTH	WEIGHT	BOX COUNT	PURCHASE UNIT
CAS4PS	HEAVY-DUTY	4"	2"	4 LB	20	1 CASTER
CAS5PS	HEAVY-DUTY	5"	2"	4.6 LB	10	1 CASTER
CAS5PS-NM	NON-MARKING	5"	2"	4.2 LB	10	1 CASTER



DUMP CART WHEELS

ITEM CODE	WHEEL TYPE	WHEEL DIAMETER	WHEEL WIDTH	WEIGHT	BOX COUNT	PURCHASE UNIT
CAS10	HEAVY-DUTY	10"	2-3/4"	7 LB	2	1 WHEEL
CAS12	HEAVY-DUTY	12"	3"	11 LB	2	1 WHEEL
CAS12-NM	NON-MARKING	12"	3"	3 LB	2	1 WHEEL



MAGNUM[®]

Magnum Tool Corp., Inc.
5600 Bonhomme Rd, Suite B
Houston, TX 77036

1 (888) 443-8889 fax (713) 781-5677

sales@magnum-tool.com

www.magnum-tool.com