

MAGNUM

®

WE HANDLE IT™

DUMP CARTS

PRO SERIES



PRO SERIES

***BUILT TO HANDLE
THE WORK THAT
DOESN'T LET UP.***

Magnum Pro-Series Dump Carts have become one of our signature material handling products. Each cart is designed around a premium injection-molded tub, easy-clean surfaces, and durable wheel and caster options for dependability across demanding jobsites. With multiple capacities, heavy-duty frame configurations, lid options, and replacement parts available, the Pro-Series Dump Cart lineup gives crews a dependable system for moving, dumping, storing, and handling heavy loads day after day.



The digital version of this document has been enhanced with hyperlinks that link to product detail pages on magnum-tool.com

THE LINE

AT A GLANCE



All dump carts come standard with premium injection-molded tubs and heavy-duty wheels and casters for lasting durability, unless marked -NM for Non-Marking wheels and casters. Enhanced frame options are also available for customers hauling serious weight, and we stock replacement parts and accessories to keep you rolling.

1/2 CU. YD. DUMP CARTS

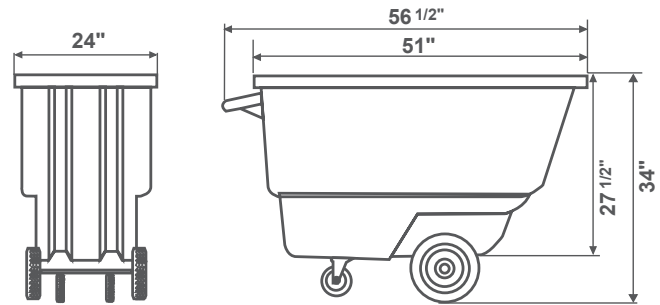

1/2 CU. YD. DUMP CARTS

**DUC12T
DUC12T-NM**

PG. 6

1/2 CU. YD. FORKLIFT-READY DUMP CARTS

**DUC12T-F
DUC12T-F-NM**

PG. 7

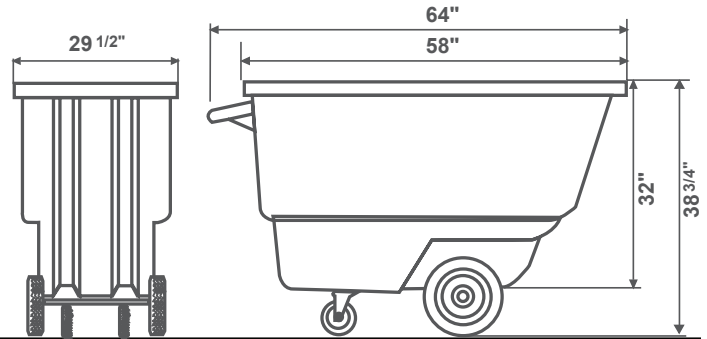

1 CU. YD. C.C. DUMP CARTS



1 CU. YD. COVERED CAPACITY DUMP CARTS

**DUC100-12
DUC100-12-NM**

PG. 6

1 CU. YD. COVERED CAPACITY DUMP CARTS W/ REINFORCING FRAME

**DUC100-R
DUC100-R-NM**

PG. 7

1 CU. YD. COVERED CAPACITY DUMP CARTS W/ HEAVY-DUTY FULL FRAME

**DUC100-H
DUC100-H-NM**

PG. 7

1 CU. YD. COVERED CAPACITY FORKLIFT-READY DUMP CARTS

**DUC100-F
DUC100-F-NM**

PG. 7



DUMP CARTS

Engineered for industrial and commercial use, these durable injection-molded tubs support load capacities ranging from 750 to 1,250 lbs. Available in 1/2 cubic yard and 1 cubic yard covered capacity, each dump cart is built with a variety of reinforced frame options to meet demanding jobsite needs.

Designed for smooth maneuverability and equipped with robust wheel and caster configurations, these carts are also easily stackable, ensuring efficient storage and transport.

OPTIONAL LID

RUGGED & DURABLE
CONSTRUCTION

REINFORCED
EDGES

A VARIETY
OF FRAME
OPTIONS

DOUBLE
INJECTION
MOLD

HEAVY-DUTY & NON-MARKING
CASTER & WHEEL OPTIONS



MAGNUM



EASY STACKING. EFFICIENT STORAGE.

MAGNUM

WE HANDLE IT™



888.443.8889



MAGNUM-TOOL.COM

DUMP CARTS

- Premium injection molded tubs for added strength in corners
- Smooth surface is easy to clean and resists corrosion
- Fits through standard doorways and elevators
- Handling can be performed by a single user
- Construction grade wheels and casters



1/2 Cubic Yard Dump Cart

750 LB LOAD CAPACITY

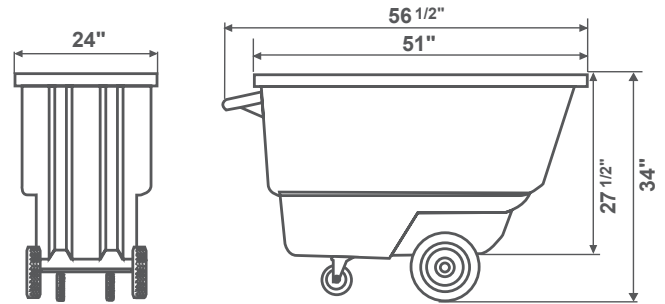

| ITEM CODE | CASTER TYPE | WHEEL TYPE | ITEM WEIGHT | PALLET COUNT |
|------------|----------------|-----------------|-------------|--------------|
| DUC12T | 4" HEAVY-DUTY | 10" HEAVY-DUTY | 64 LB | 14 |
| DUC12T-NM* | 5" NON-MARKING | 12" NON-MARKING | 48 LB | 14 |

*Use 2-5/8" Axle (DUA12-575)

1 Cubic Yard Covered Capacity Dump Cart

800 LB LOAD CAPACITY

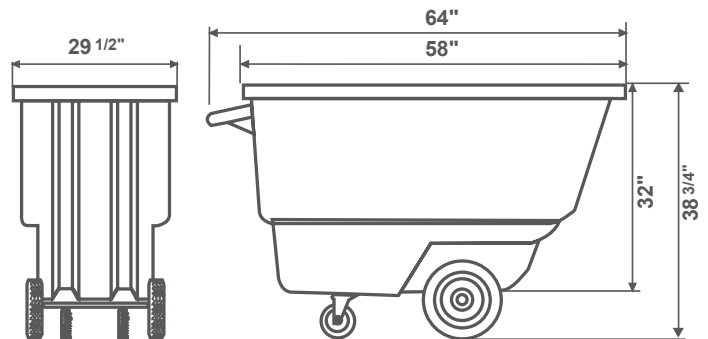

| ITEM CODE | CASTER TYPE | WHEEL TYPE | ITEM WEIGHT | PALLET COUNT |
|--------------|----------------|-----------------|-------------|--------------|
| DUC100-12 | 5" HEAVY-DUTY | 12" HEAVY-DUTY | 89 LB | 12 |
| DUC100-12-NM | 5" NON-MARKING | 12" NON-MARKING | 73 LB | 12 |



**1 Cubic Yard Covered Capacity Dump Cart w/
Reinforcing Frame**

UP TO 1000 LB LOAD CAPACITY

| ITEM CODE | CASTER TYPE | WHEEL TYPE | LOAD CAPACITY | ITEM WEIGHT | PALLET COUNT |
|-------------|----------------|-----------------|---------------|-------------|--------------|
| DUC100-R | 5" HEAVY-DUTY | 12" HEAVY-DUTY | 1000 LB | 94 LB | 12 |
| DUC100-R-NM | 5" NON-MARKING | 12" NON-MARKING | 900 LB | 78 LB | 12 |



**1 Cubic Yard Covered Capacity Dump Cart w/
Heavy-Duty Full Frame**

UP TO 1200 LB LOAD CAPACITY

| ITEM CODE | CASTER TYPE | WHEEL TYPE | LOAD CAPACITY | ITEM WEIGHT | PALLET COUNT |
|-------------|----------------|-----------------|---------------|-------------|--------------|
| DUC100-H | 5" HEAVY-DUTY | 12" HEAVY-DUTY | 1200 LB | 112 LB | 10 |
| DUC100-H-NM | 5" NON-MARKING | 12" NON-MARKING | 950 LB | 96 LB | 10 |

**MAGNUM HEAVY-DUTY
FORKLIFT READY DUMP CARTS**



**UP TO
1250 LB LOAD
CAPACITY**

Compatible with forklifts and automated lifters. Features a heavy-duty forklift ready frame that is built to last.



| ITEM CODE | DESCRIPTION | LOAD CAPACITY | CASTER TYPE | WHEEL TYPE | ITEM WEIGHT | PALLET COUNT |
|-------------|---|---------------|----------------|-----------------|-------------|--------------|
| DUC12T-F | 1/2 CU. YD. FORK LIFT READY DUMP CART, HD | 850 LB | 5" HEAVY-DUTY | 12" HEAVY-DUTY | 79 LB | 8 |
| DUC12T-F-NM | 1/2 CU. YD. FORK LIFT READY DUMP CART, NM | 850 LB | 5" NON-MARKING | 12" NON-MARKING | 63 LB | 8 |
| DUC100-F | 1 CU. YD. COVERED CAPACITY FORKLIFT READY DUMP CART, HD | 1250 LB | 5" HEAVY-DUTY | 12" HEAVY-DUTY | 103 LB | 7 |
| DUC100-F-NM | 1 CU. YD. COVERED CAPACITY FORKLIFT READY DUMP CART, NM | 1000 LB | 5" NON-MARKING | 12" NON-MARKING | 87 LB | 7 |

Premium steel powder coated frames resist corrosion.

DUF100R

Reinforcing Frame for 1 Cubic Yard Covered Capacity Dump Cart

Add to any existing 1 CU. YD. Covered Capacity Dump Cart. No additional hardware needed.



ITEM WEIGHT
5 LB

PURCHASE UNIT
1 FRAME

DUF100H

Heavy Duty Frame for 1 Cubic Yard Covered Capacity Dump Cart

Add to any existing 1 CU. YD. Covered Capacity Dump Cart. No additional hardware needed.



ITEM WEIGHT
23 LB

PURCHASE UNIT
1 FRAME

DUF12F-K

Forklift Ready Frame Kit for 1/2 Cubic Yard Dump Cart

Includes: (1) Forklift Ready Frame, (2) Heavy-Duty 5" Casters, (2) Heavy-Duty 12" Wheels and (1) DUA12-575 Axle.



ITEM WEIGHT
18 LB

PURCHASE UNIT
1 FRAME

DUF100F

Forklift Ready Frame for 1 Cubic Yard Covered Capacity Dump Cart

Add to any existing 1 CU. YD. Covered Capacity Dump Cart. No additional hardware needed.



ITEM WEIGHT
21 LB

PURCHASE UNIT
1 FRAME

DUMP CART LIDS & ACCESSORIES

DUMP CART FABRIC LIDS



DUL12T-F

Soft Fabric Lid for Magnum 1/2 Cubic Yard Dump Cart

DIMENSIONS 51" X 29" X 6.75"
ITEM WEIGHT 3.50 LB

DUL-F

Universal Soft Fabric Lid for 1 Cubic Yard Covered Capacity Dump Cart

DIMENSIONS 67" X 29" X 6.75"
ITEM WEIGHT 3.75 LB

DUL100-F

Soft Fabric Lid for Magnum 1 Cubic Yard Covered Capacity Dump Cart

DIMENSIONS 55" X 29" X 6.75"



DUMP CART PLASTIC LIDS

Plastic Lid for 1/2 Cubic Yard Dump Cart

DUL12T

ITEM WEIGHT 12 LB
PURCHASE UNIT 1 LID

Plastic Lid for 1 Cubic Yard Covered Capacity Dump Cart

DUL100

ITEM WEIGHT 17 LB
PURCHASE UNIT 1 LID

DUMP CART AXLES



| ITEM CODE | WORKS WITH | AXLE LENGTH | WEIGHT | BOX COUNT | PURCHASE UNIT |
|------------|---------------------------------|-------------|--------|-----------|---------------|
| DUA12-550 | 1/2 CU. YD. CART | 21-5/8" | 3 LB | 1 | 1 AXLE |
| DUA12-575* | 1/2 CU. YD. CART | 22-5/8" | 3.3 LB | 1 | 1 AXLE |
| DUA100-12 | 1 CU. YD. COVERED CAPACITY CART | 24-3/8" | 4 LB | 1 | 1 AXLE |

*Use this axle on 1/2 cubic yard dump carts (DUC12T-NM and DUC12T-F) when using 5" non-marking casters (CAS5PS-NM) & 12" non-marking wheels (CAS12-NM).



DUMP CART PLATE CASTERS



| ITEM CODE | CASTER TYPE | WHEEL DIAMETER | WHEEL WIDTH | WEIGHT | BOX COUNT | PURCHASE UNIT |
|-----------|-------------|----------------|-------------|--------|-----------|---------------|
| CAS4PS | HEAVY-DUTY | 4" | 2" | 4 LB | 20 | 1 CASTER |
| CAS5PS | HEAVY-DUTY | 5" | 2" | 4.6 LB | 10 | 1 CASTER |
| CAS5PS-NM | NON-MARKING | 5" | 2" | 4.2 LB | 10 | 1 CASTER |



DUMP CART WHEELS



| ITEM CODE | WHEEL TYPE | WHEEL DIAMETER | WHEEL WIDTH | WEIGHT | BOX COUNT | PURCHASE UNIT |
|-----------|-------------|----------------|-------------|--------|-----------|---------------|
| CAS10 | HEAVY-DUTY | 10" | 2-3/4" | 7 LB | 2 | 1 WHEEL |
| CAS12 | HEAVY-DUTY | 12" | 3" | 11 LB | 2 | 1 WHEEL |
| CAS12-NM | NON-MARKING | 12" | 3" | 3 LB | 2 | 1 WHEEL |



MAGNUM[®]

Magnum Tool Corp., Inc.
5600 Bonhomme Rd, Suite B
Houston, TX 77036

1 (888) 443-8889

fax (713) 781-5677

sales@magnum-tool.com

www.magnum-tool.com