

MAGNUM[®]

SAFE-CUT

Mobile Cutting Station

- Lightweight and portable for easy mobility around the worksite, even up stairs
- Mobile cutting station purpose-built for safety, and productivity
- Adds protection from sparks, and debris, while providing storage

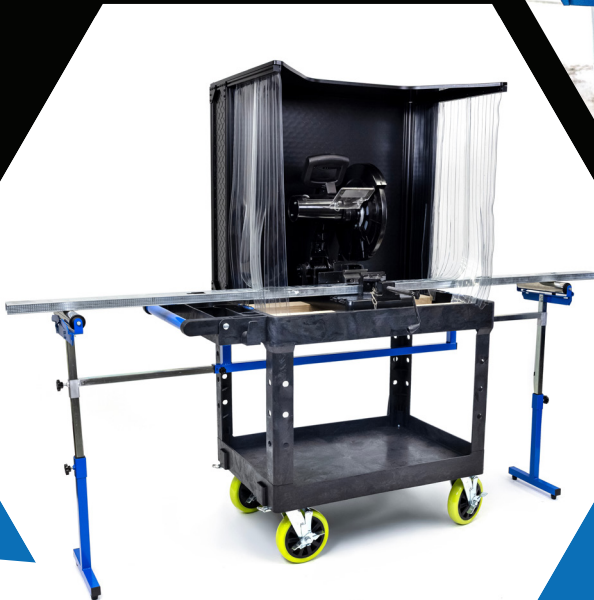

**Safety.
Mobility.
Productivity.**

A worksite-ready answer for cutting materials to length with control and confidence, the **Magnum Safe-Cut Mobile Cutting Station** creates a mobile cutting area and added storage on our rugged Pro-Series service cart platform, right where the crew is working. Includes everything but the saw. Easy to assemble.

- Mobile cutting station built for miter saws and chop saws
- Compact, easy-rolling design that reduces trips to a fixed cutting area
- Safety focused construction that stands up to heavy use while helping shield workers and surroundings from sparks and debris



SCAN FOR DETAILS

MAGNUM[®]

WE HANDLE IT[™]



888.443.8889



MAGNUM-TOOL.COM

SAFE-CUT



Compact, lightweight design for mobility



Adjustable material supports for long material



Rugged diamond plate panels, and extruded framing



3-sides of protection from sparks and debris



8" Max-Endurance Casters, four (4) swivel w/ brakes

Magnum Safe-Cut Mobile Cutting Station

CART4426-APP-CT

UPC: 782156074257

SPECIFICATIONS

Net Weight: 145 lbs (Cart, Enclosure, Material Supports, and Casters)

Gross Weight: 153 lbs

Load Capacity: 500 lbs

Overall Dimensions (L x W x H): 44" x 26" x 64"

Material Construction:

- **Service Cart** - Rugged polypropylene structural foam for unmatched durability. Premium injection molding.
- **Enclosure** - Rigid aluminum panels walls (diamond-plate), aluminum frame extrusions, and removable PVC curtains
- **Material Supports** - Powder coated steel frame, steel rollers. Adjustable up to 38 inches tall and 10 feet in length.
- **Casters** - Heavy-duty polyurethane, 8" Max-Endurance Casters (4 swivel with brakes and directional locks)

Ships in two separate boxes.

APPLICATIONS

- **Drywall contractors** cutting steel stud and track
- **Framers** working with long material runs
- **Electrical, Mechanical, and HVAC** workers cutting conduit, tubing, and channel
- **Commercial work sites** where safety, production, and lightweight mobility matters

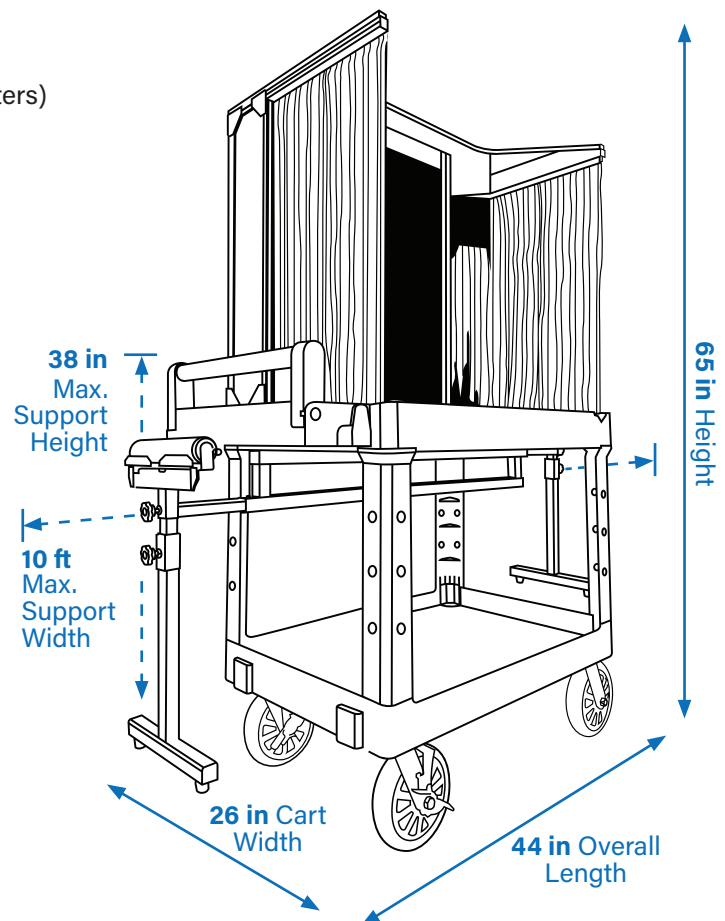

MAGNUM

WE HANDLE IT™



888.443.8889



MAGNUM-TOOL.COM